

# Diode Testing Procedure

## FORWARD AND REVERSE BIAS TESTING

### Multimeters: Analog versus digital, the service manuals forgot one important detail

They were written in the era of the analog multimeter. Unfortunately, the manufacturer's have never updated this testing information and it is not accurate for today's digital testing multimeters.



Older Analog Multimeter

Newer Digital Multimeter

### Why is this so important?

Following the service manual testing procedure for the regulator/rectifier using a modern digital multimeter will result in results that are incorrect. Most rectifiers will test bad, while they're still fine!

### What's inside an ElectroSport RR?

You will find three YELLOW wires on the outside going into the part. Each YELLOW wire connects to 2 diodes, for a total of 6 diodes. To understand this more clearly, see the illustration below. Note: A diode is defined with an arrow with a bar over the top. There is also a regulator circuit for controlling the output voltage. This circuit is not easy to test without special equipment, so we do not cover it here. If a regulator/rectifier fails, what usually fails is one of the diodes, not the regulator circuit.

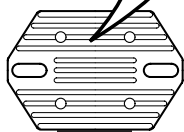
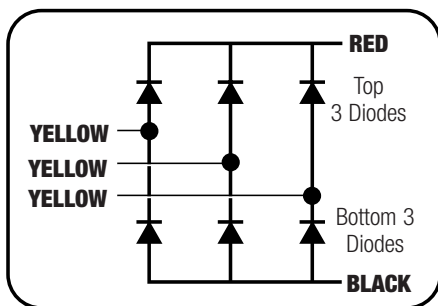

Note: The RED wire could be WHITE/RED, and the BLACK wire could be GREEN or BLACK/WHITE or BLACK/YELLOW depending upon your motorcycle brand.

### Top Diode Tests

#### Getting Started

We suggest using a FLUKE™ model 110 digital multimeter. It's one of the best in the business and is very affordable. To begin the test, switch the knob on the multimeter to the "DIODE" selection as shown in figure A.

#### Forward Bias: Top 3 Diodes - Test 1.

From the multimeter connect the BLACK test connector to the RED wire coming from the regulator rectifier. Then from the multimeter connect the RED test connector to ONE of the YELLOW wires coming from the regulator rectifier. The readout should show between 0.400-0.600 along with a single audible beep as shown in (Figure A). Continue by testing the remaining YELLOW wires following the same test procedure.

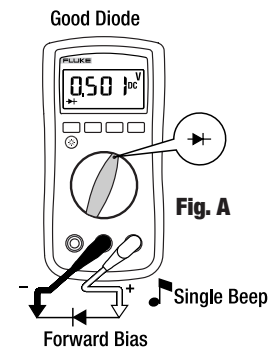

**When a diode is bad:** You'll hear a continuous tone with a readout of 0.000 as shown in (Figure C) *or* the readout will indicate any number value other than 0.400-0.600 shown in (Figure B) *or* the readout will indicate "OL" as shown in (Figure D).

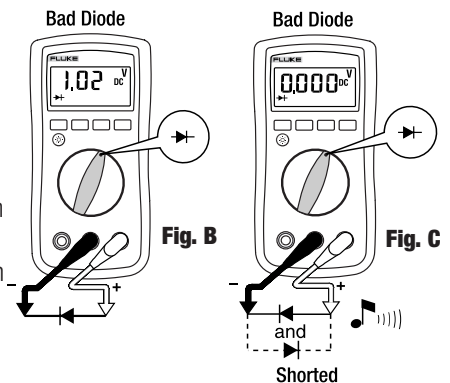

#### Reverse Bias: Top 3 Diodes - Test 2.

From the multimeter connect the RED test connector to the RED wire coming from the regulator rectifier. Then from the multimeter connect the BLACK test connector to ONE of the YELLOW wires coming from the regulator rectifier. The display should show "OL" as shown in (Figure D). Continue by testing the remaining YELLOW wires following the same test procedure.

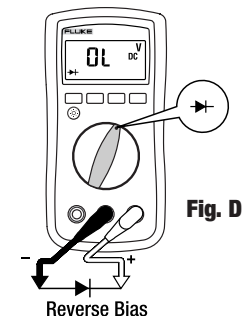

**When a diode is bad:** You'll hear a continuous tone with a readout value of 0.000 shown in (Figure C) *or* the readout will indicate ANY number value (Figure B).

### Bottom Diode Tests

#### Getting Started

To begin the test, switch the knob on the multimeter to the "DIODE" selection as shown in figure A.

#### Forward Bias: Bottom 3 Diodes - Test 1.

From the multimeter connect the RED test connector to the BLACK wire coming from the regulator rectifier. Then from the multimeter connect the BLACK test connector to ONE of the YELLOW wires coming from the regulator rectifier. The readout should show between 0.400-0.600 along with a single audible beep as shown in (Figure A). Continue by testing the other YELLOW wires following the same testing procedure.

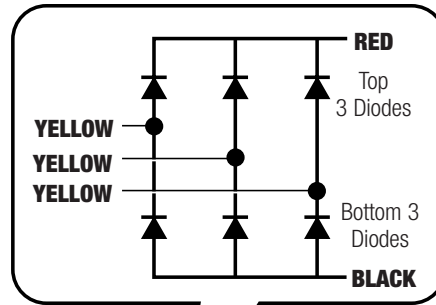
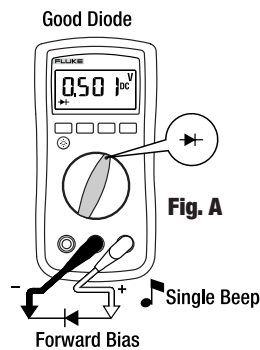

*Note: The RED wire could be WHITE/RED, and the BLACK wire could be GREEN or BLACK/WHITE or BLACK/YELLOW depending upon your motorcycle brand.*

#### When a diode is bad:

You'll hear a continuous tone with a readout of 0.000 as shown in (Figure C) *or* the readout will indicate any number value other than 0.400-0.600 shown in (Figure B) *or* the readout will indicate "OL" as shown in (Figure D).

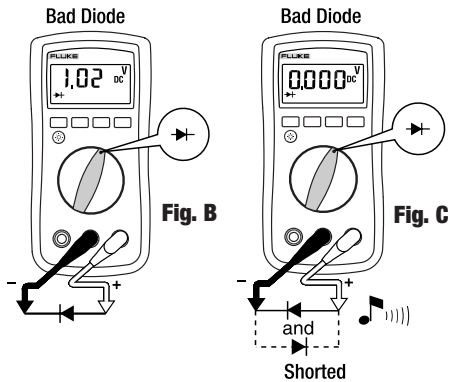

### Looking for more information

**Go to the ElectroSport website: [www.electrosport.com](http://www.electrosport.com)**

You can download the fault finding chart which will provide you an in-depth understanding and testing procedures for your entire electrical and charging system.

Also, be sure to check out the technical archive for specific ElectroSport product information and installation instructions. If your looking for information regarding your bike model and an ElectroSport product please see the application listing for products. You can then double click on your bike model and year and see specific information regarding your bike and the ElectroSport part which works with it.

#### Reverse Bias: Bottom 3 Diodes - Test 2.

From the multimeter connect the BLACK test connector to the BLACK wire coming from the regulator rectifier. Then from the multimeter connect the RED test connector to ONE of the YELLOW wires coming from the regulator rectifier. The display should show "OL" as shown in (Figure C). Continue by testing the other YELLOW wires following the same testing procedure.

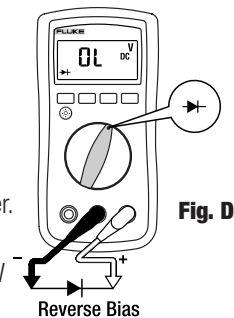

**When a diode is bad:** You'll hear a continuous tone with a readout value of 0.000 shown in (Figure C) *or* the readout will indicate ANY number value (Figure B).